

- Emergency LED Driver
- Universal Voltage: 100-277VAC, 50/60Hz
- Output Wattage: 1-10W
- Output Current: 300mA Max.
- Output voltage :6VDC

This Driver Will Operate The Following LED Modules: Any LED module designed to accept input voltage of 6VDC and can operate up to current of 300mA.

General Specifications

Input Voltage	100-277VAC, 50/60Hz
Input Current	0.06A Max.
Input Power	10W MAX
Standby Input Power	<0.8W
Driver Type	Constant Voltage
Output Current	300mA Max.
Output Voltage	6VDC
Output Power	1-10W (1-6W @ 3000mA Battery, 1-8W @ 4000mA Battery, 1-10W @ 8000mA Battery)
Number of Output Channels	1 Channel
RFI/EMI	FCC Part 15 Class A
Output Type	LED Class 2
Battery Type	NiCd 3.6VDC
Battery Capacity Available	3000mAh, 4000mAh, 8000mAh
Battery Recharge Time	32 Hours (3000mAh), 32 Hours (4000mAh), 48 Hours (8000mAh),
Battery Discharge Time	90 Minutes Min.
Ambient Operating Temperature Range	0°C to 50°C (32°F to 122°F)
Input Surge Protection	MOV
Protections	Output Short Circuit Protection Battery Over Discharge Protection
Service Life	50,000 hours
Approvals / Class	UL 1310/CLASS 2/UL924/CEC

Mechanical Data

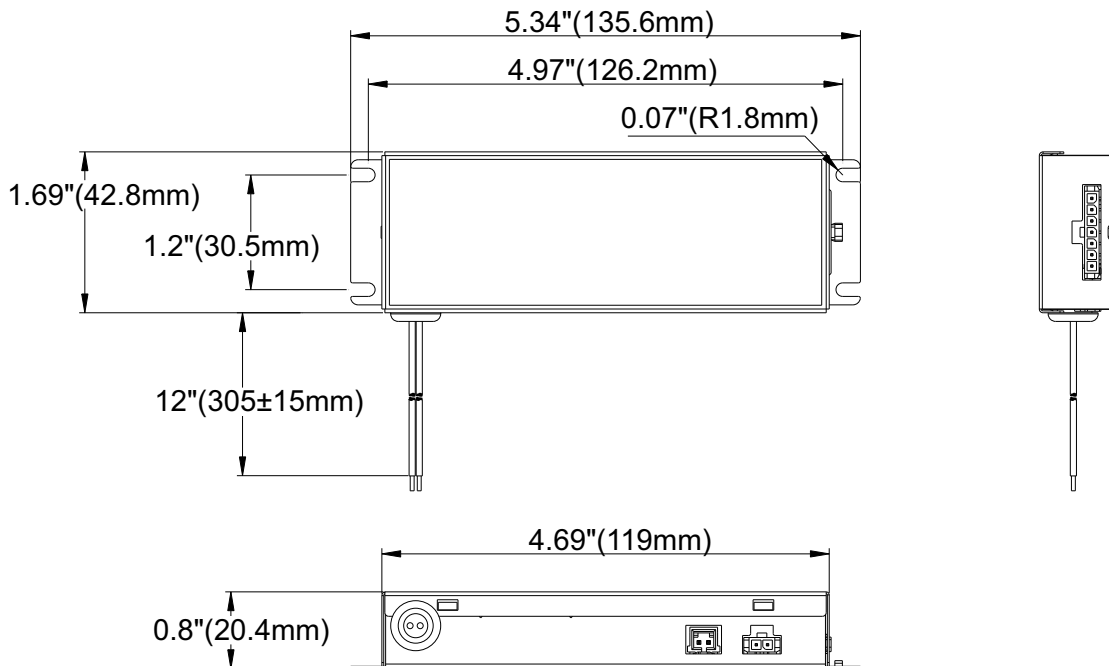

Case Tolerance=±0.02"

Fulham extends a limited warranty to the original purchaser or first user for a period of 5 years from the date of manufacture when properly installed and operated under normal conditions of use. For complete terms and conditions, please refer to the Warranty Center at www.fulham.com. Specifications subject to change without notice.

Wiring Diagrams 1

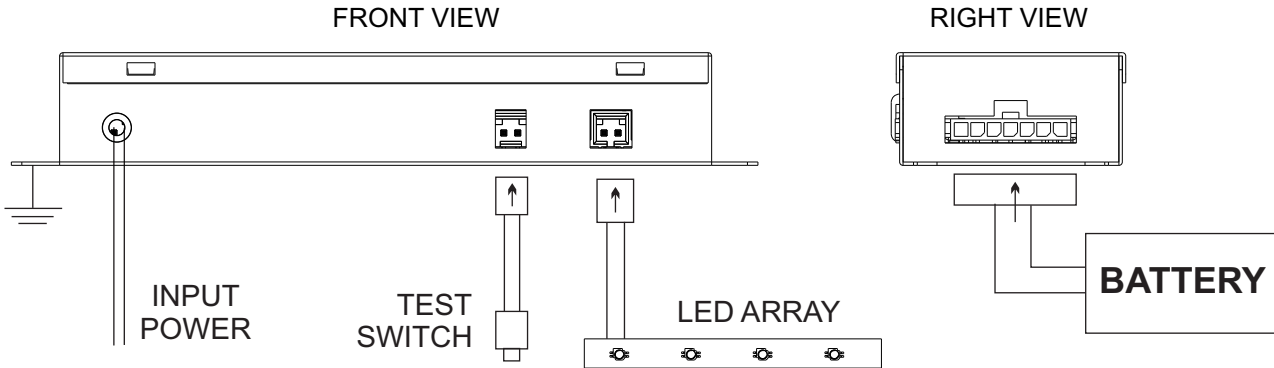

WIRING DIAGRAM (TYP)

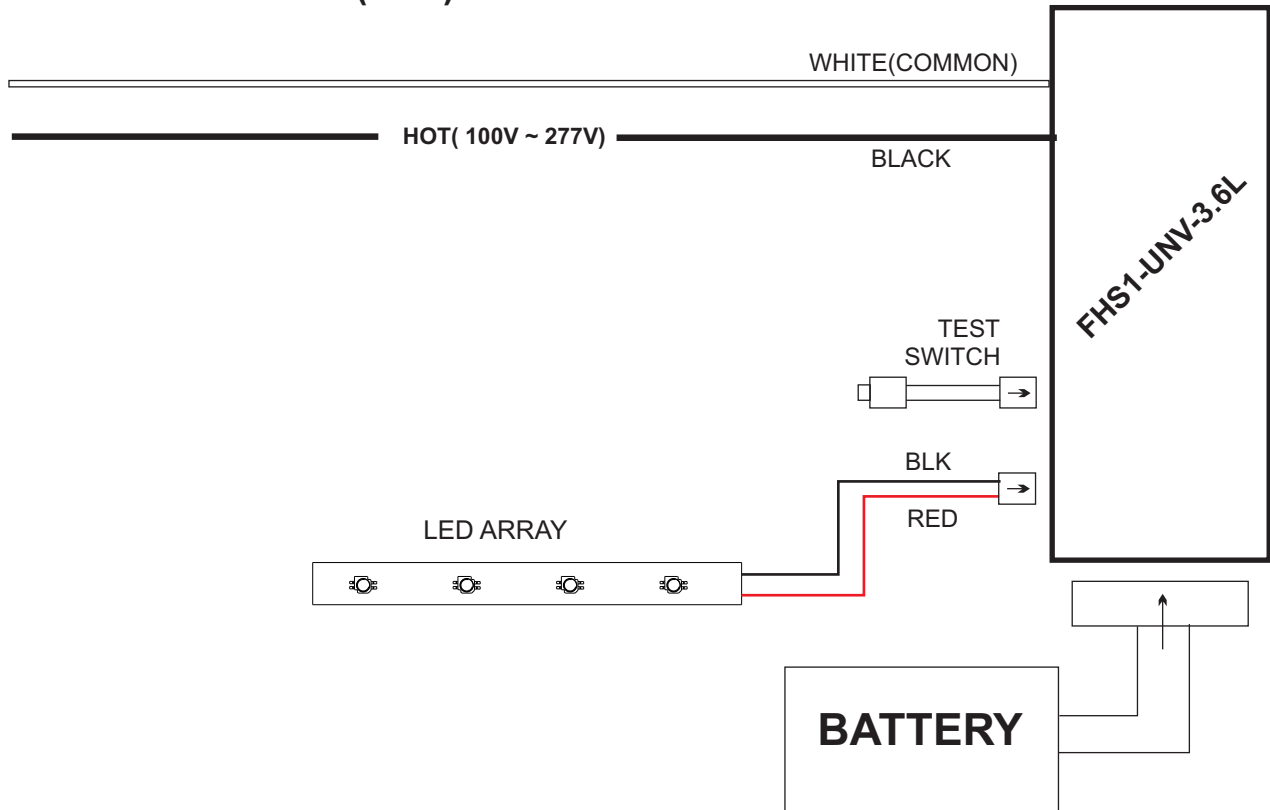

Fulham extends a limited warranty to the original purchaser or first user for a period of 5 years from the date of manufacture when properly installed and operated under normal conditions of use. For complete terms and conditions, please refer to the Warranty Center at www.fulham.com. Specifications subject to change without notice.

Available battery pack

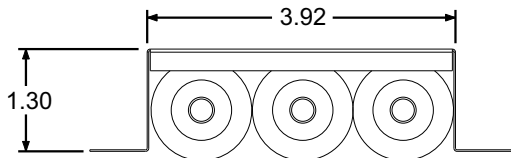
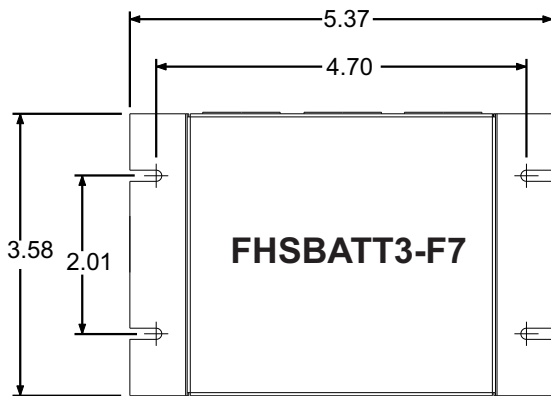
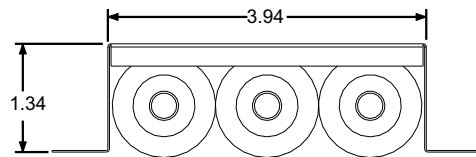
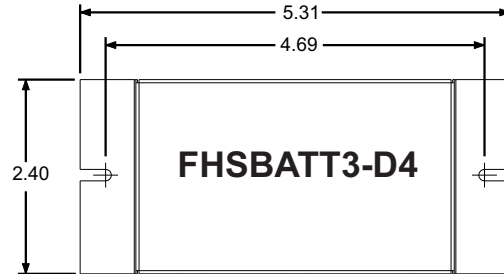
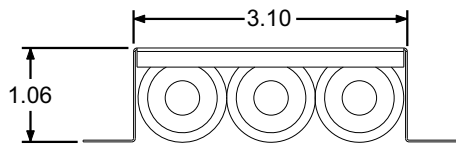
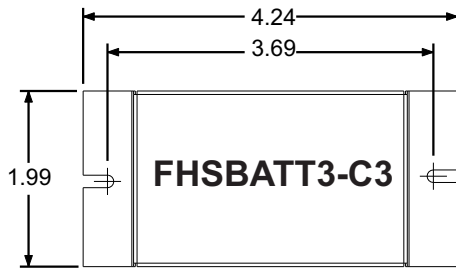

Battery Pack	Output Power	Time		
FHSBATT3-C3	4W	145 Minutes		
FHSBATT3-C3	6W	90 Minutes		
FHSBATT3-D4	4W	200 Minutes		
FHSBATT3-D4	6W	125 Minutes		
FHSBATT3-D4	8W	90 Minutes		
FHSBATT3-F7	4W	360 Minutes		
FHSBATT3-F7L				
FHSBATT3-F7			6W	235 Minutes
FHSBATT3-F7L				
FHSBATT3-F7	8W	175 Minutes		
FHSBATT3-F7L				
FHSBATT3-F7			10W	135 Minutes
FHSBATT3-F7L				

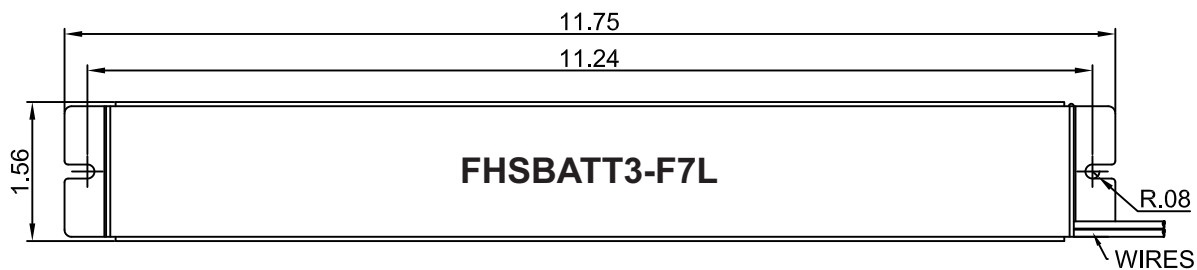
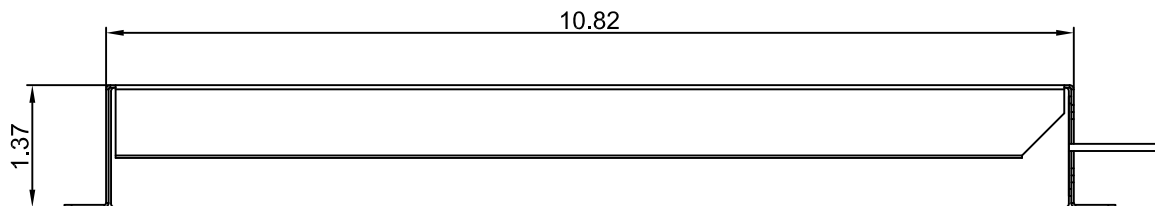

Available array shapes

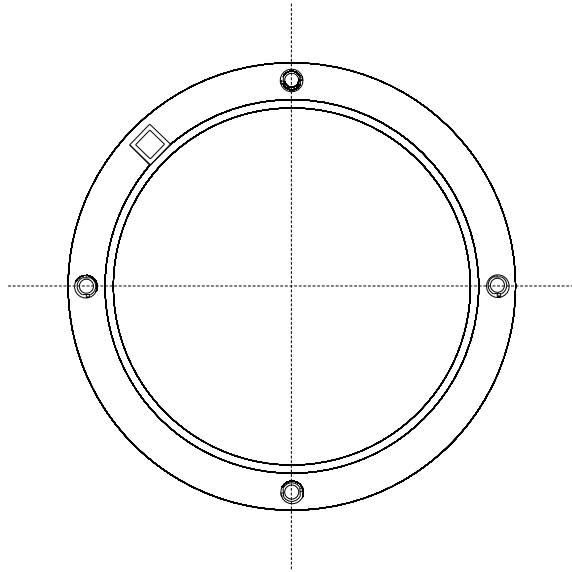

FHS2-AR-4W-C

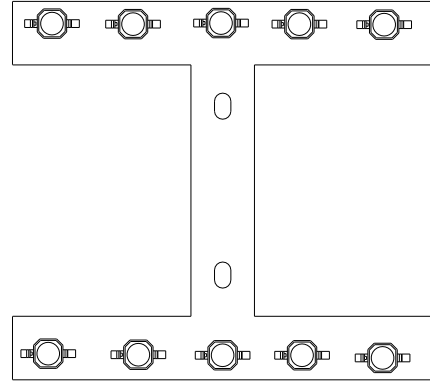

FHS3-AR-10W-SH
FHS3-AR-6W-SH

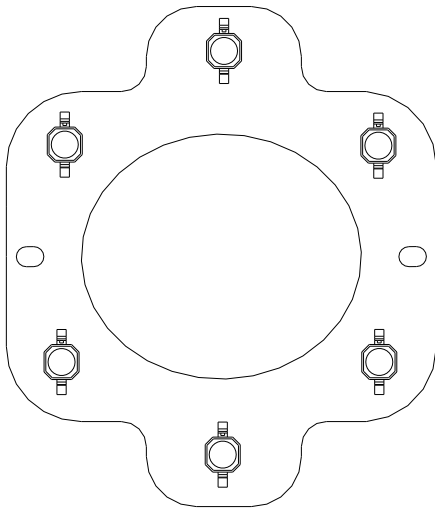

FHS5-AR-6W-CL

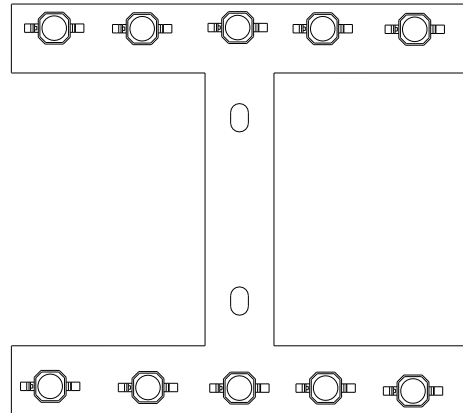

FHS4-AR-10W-LH
FHS4-AR-8W-LH

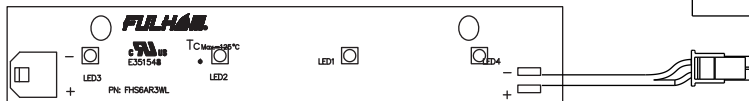

FHS6-AR-3W-L

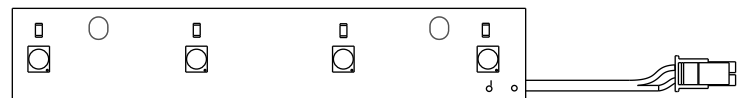

FHS1-AR-4W-L

TEST SWITCH INDICATOR STATUS:

FHS1-UNV-3.6L Status Indication - Single Color Indicator			
LED indicator	Status	Comment	Note
Permanent Red Light/Solid	System OK	AC mode	
Blinking ON (4.5 sec on – 0.5 sec off)	Self-diagnose test underway	Self-Diagnostic	
Blinking OFF (0.5 sec on – 4.5 sec off)	Charge circuit is broken	Replace EM Driver	
Fast Flashing (0.5 sec on - 0.5 sec off)	Battery not connected	Connect battery pack.	
Fast Flashing (0.5 sec on - 0.5 sec off)	Battery failure	Change the battery	
Very Slow Flashing (4 sec on – 4 sec off)	Over Circuit Protection Error Triggered.	Check LED load or check EM driver.	AC power will need to be cycled on/off as well as the battery re-inserted.

TEST SWITCH OPERATIONS:

1. EM TEST : Press and hold test button for more than one second to enter EM mode for testing.
2. Manual Self-Diagnostic : After charging the battery for the specified recharge time, quickly press the test button three times within two seconds to force the controller to enter a Self-Diagnostic cycle. To quit the self-diagnostic cycle after engaged press and hold the test button for ten seconds.
3. Enable/Disable Self-Diagnostic Status : Quickly press the test button two times within two seconds ,the monochromatic lamp displays the status of Self-Diagnostic Enable / Disabled settings.
4. Enable/Disable Auto Self-Diagnostic : Press and hold the test button for two seconds, then release and quickly press the test button two times, then release and press and hold the test button for two more seconds. When properly executed the indicator on the test button will display the flash mode for the Enable/Disable status. A flash of 2.5S on - 0.5S off means "Enabled", while a flash of 0.5S on - 2.5S off means "Disabled", the flashing will last for a few cycles.

SELF- DIAGNOSTIC INSTRUCTIONS / OPERATION:

If the self-diagnostic feature is enabled:

The emergency LED driver will conduct a self-check for thirty (30) seconds every thirty (30) days; and a ninety (90) minute self-check every 12 months. After every self-check the LED indicator light will indicate a status signal. Check indicator status chart above to diagnose the status signal.

If the self-diagnostic feature is disabled:

User must conduct a manual test every thirty (30) days to ensure the emergency LED light source illuminates as intended. A full discharge test shall be conducted once a year; the LED light source shall illuminate for a minimum of ninety (90) minutes.

***Self-Diagnostic feature is factory disabled**