



T1M1UNV0700-30L

SELV



IP64



RoHS COMPLIANT

36W Constant Current LED Driver

- Input Voltage: 120V-277V~ - 50-60Hz
- Constant Current 700mA
- Class 2 LED Driver
- Output Voltage Range of 18-45V ---
- Output Power: 30W Max.
- U-OUT: 60V---
- 0-10V Dimmable: 100%-10%
- Flicker <7%, meets CEC requirement

General Specifications

Input Voltage / Frequency	120-277VAC (+/- 10%), 50-60Hz
Input Current	0.13A - 0.3A
Input Power	36W (Max.)
Input PF	>0.9
THD	<20%
Efficiency	86% Typical
Inrush Current / Time	<20A @277V / 250us
Max Leakage Current	<0.7mA @240V per CE / <0.75mA@277V per UL
Output Voltage Range	18-45V ---
Output Current	700mA
Line Regulation / Load Regulation	<1% @100% Load / <3% @Full Load
Total Overall Ripple LF (<300Hz)/ HF(<40kHz)peak to peak	<5% @Full Load / <5% @Full Load
Low Frequency Ripple (120Hz ripple peak to peak)	<5% @Full Load
Flicker Percentage	<7% @100% - 20% Dimming Rang <5% @ <20% Dimming Rang
Dimming Isolation	0-10VDC to AC basic isolated
Operating Ambient Temperature Range	-40°C to 62°C (-40°F to 143.6°F)
Maximum Driver Case Temperature (Tc) (Per UL)	85°C (185°F)
Start-up Time	<500ms
Standby Power	<0.5W
Driver Output Type / Number of Output Channels	Constant Current - LED Class 2 / 1 Channel
Overall Size	4.65" L x 1.18" W x 1.16" H (118mm L x 30mm W x 29.5mm H)
Wire Type / Length	18AWG / 12" Black & White 18AWG / 6" Red & Blue 20AWG / 12" Gray & Purple wires
Weight	222.26g / 0.49lbs.
Safety / Compliance	EN61347-1, EN61347-2-13, UL8750,1310 cULus Listed Class P, E342838 RoHS Compliant SELV Compliant BIS Compliant CCC CE Suitable for Dry, Damp, and Wet locations (IP64)
Withstand Voltage	I/P-O/P:3750VAC, I/P-FG:1750VAC, I/P-Dimming: 3750 VAC O/P-FG:500VAC
Insulation Resistance	I/P-O/P, I/P-FG, O/P-FG:100M Ohms/ 500VDC/25°C/70%RH
Potting Type / Degree of Fill	Potting As Per ASTM D36-86
EMC Emission	FCC Part 15B Consumer, EN55015,EN61000-3-2, 3
EMC Immunity	IEC61000-4-2,3,4,5,6,8,11,IEC61547
Operating Humidity	20-98% RH Non-condensing
Protections	Input Surge Line-Neutral 1KV, Line & Neutral-Ground 2KV(Ringwave 2.5KV / 2.5KV) Input Current Protection Output Short Circuit Protection(Recovers automatically after short is removed) Overload Protection Over Temperature Protection
Hot Swappable	No
Sound Rating	A
Service Life	50,000 hours lifetime @ Tc 76°C (168. 8°F), see figure 5
Warranty	5 years @ Tc 76°C (176°F) from the date of manufacture

*FG = Fault Ground **I/P = Input Power ***O/P = Output Power



Typical Characteristics Graphs: Input

Figure 1

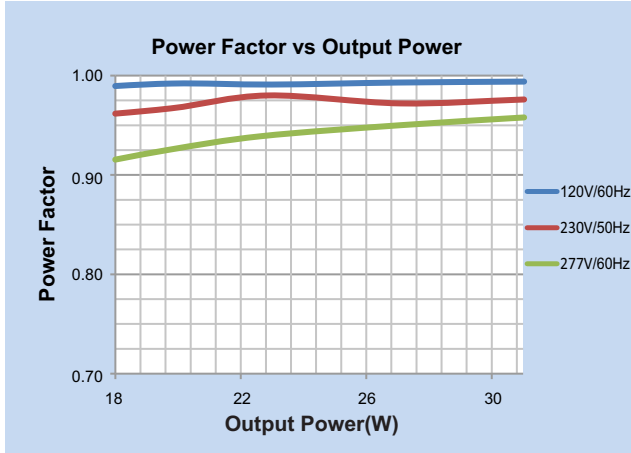

Figure 2

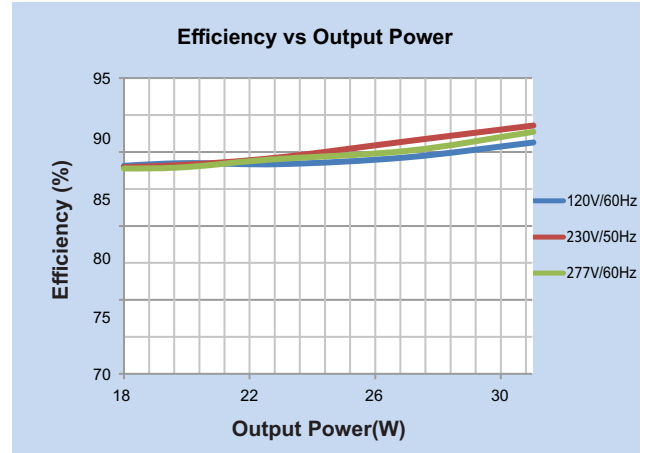
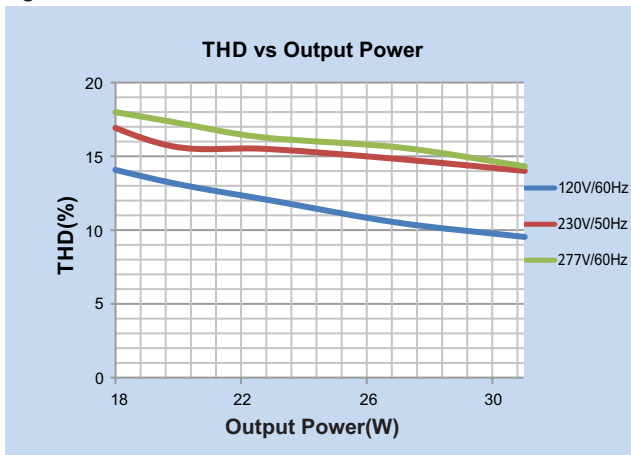

Figure 3





Typical Characteristics Graphs: Dimming and Thermal

Figure 4

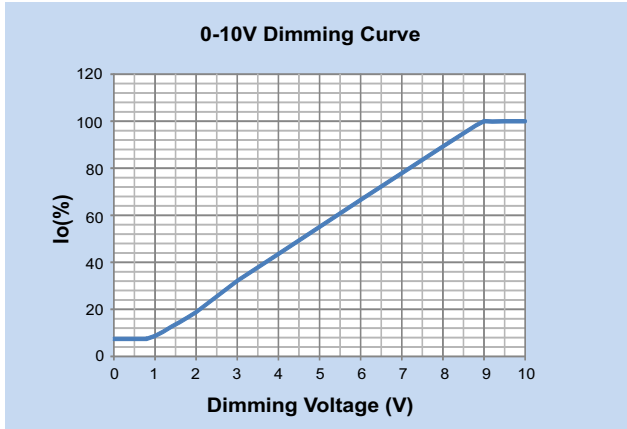
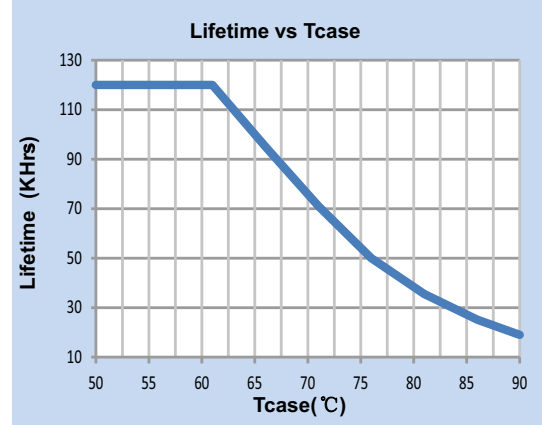
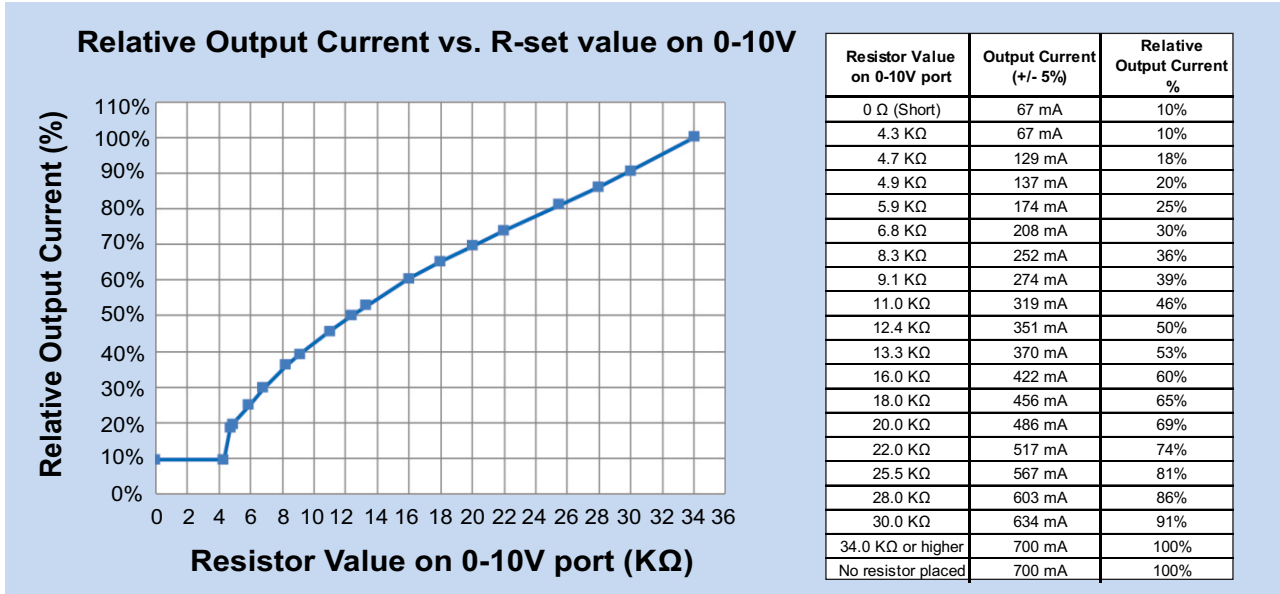

Figure 5



Failure Rate Info based upon MTBF modeling:
90% survivals at end of life @ <=Tc lifetime rating

Figure 6





T1M1UNV0700-30L

SELV



IP64



RoHS COMPLIANT

Mechanical Data

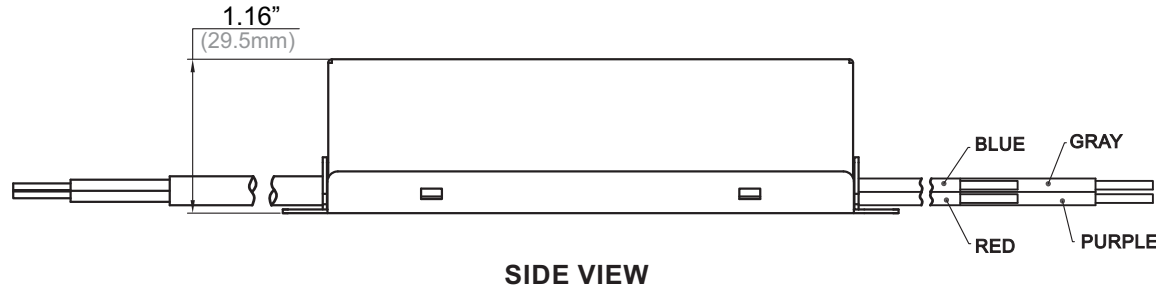
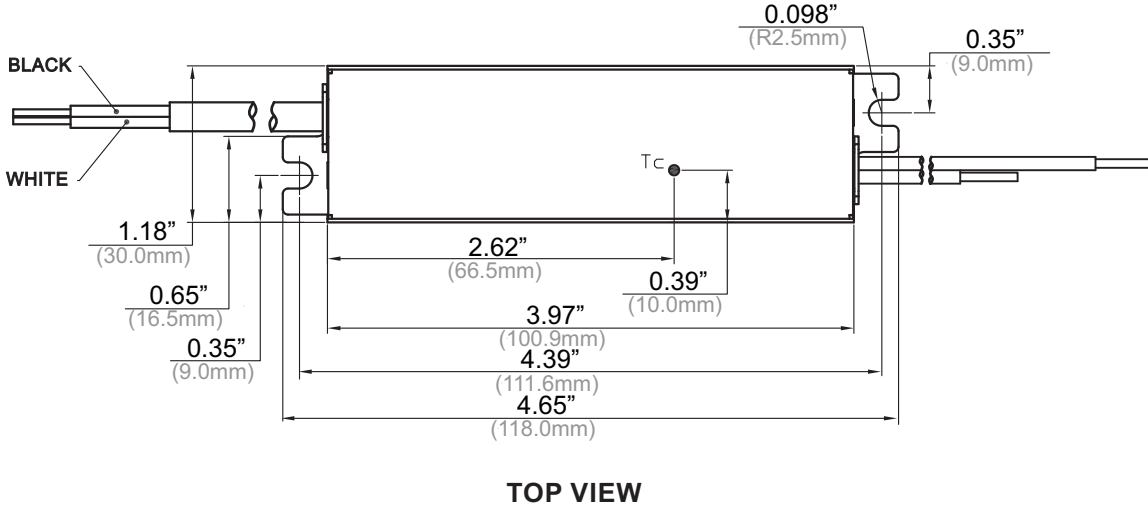

Overall Dimensions	
Length	4.65" [118mm]
Width	1.18" [30mm]
Height	1.16" [29.5mm]
Wire Length	
AC Input (White/Black)	12" [304.8mm]
LED Output Red Blue	6" [152.4mm]
LED Output Gray Purple	12" [304.8mm]

Case Tolerance=±0.02"

Wiring Diagram

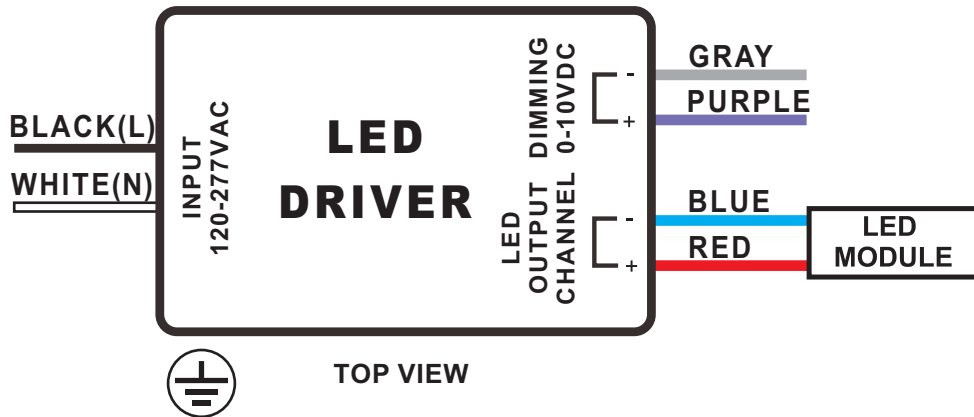

INPUT SIDE	LENGTH
BLACK	12" [304.8mm]
WHITE	12" [304.8mm]

OUTPUT SIDE	LENGTH
RED	6" [152.4mm]
BLUE	6" [152.4mm]
PURPLE	12" [304.8mm]
GRAY	12" [304.8mm]

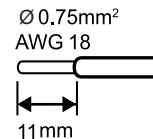

NOTE:

- 1) This Driver Must Be Installed By A Licensed Electrician
- 2) This Driver Must Be Grounded



T1M1UNV0700-30L



Guidelines

Grounding

- Driver must be grounded by means of the Driver case.

Over temperature protection

- The Fulham ThoroLED drivers is protected against thermal overload. If the temperature limit is exceeded, the output current shut down.

LED load

- Fulham ThoroLED drivers are designed to drive passive LEDs, -COB's and -LED assemblies .Proper function is not guaranteed when (LED)loads with active components are used.

Short-circuit protection

- In case of a short circuit the LED driver switches to protection mode. After the removal of the short-circuit the LED driver will recover automatically.

No-load Operation

- In no-load operation the output voltage will not exceed the specified open circuit output voltage.

Hot Swapping

- This driver does not support hot swapping of the LEDs.

Remote Mounting

- Up to 50ft with 18AWG. Contact Fulham for higher remoute distance.

Service life/Lifetime

- Failure Rate Info based upon MTBF modeling: 90% survivals at end of life @ $\leq T_c$ lifetime rating.

Warranty

- Reference Fulham's limited Warranty: <https://cdn.fulham.com/PDFs/Limited-Warranty.pdf>



T1M1UNV0700-30L



Part Number Matrix

T	1	M	1	UNV	0700	30	L
LED Driver	# of Control Channels	Dimming Type	# of Output Channels	Input Voltage	Output Current	Max. Output Power	Case Type
T = ThoroLED WorkHorse	1 = 1 Channels	M = 0-10V	1 = 1 LED Channel	UNV = 120V~277V	0700 = 700mA	30 = 30W	L = Long

Product Image: LED Driver

T1M1UNV0700-30L



Packaging

Master Carton

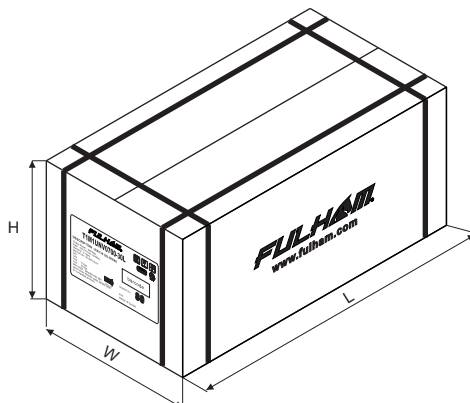

OUTER DIMENSION		
L	W	H
14.96"(380mm)	10.23"(260mm)	7.28"(185mm)
Net Weight	Gross Weight	QUANTITY
39.24 lbs. (17 kg)	42.32 lbs. (18 kg)	80pcs